

# Central Heating Module

## Model 2000-1200



### Features:

- Propane or natural gas fuel source. Can be converted to natural gas or propane with optional conversion packages.
- Compact and portable design for easy positioning on the work site.
- Water heater has a 2-stage output allowing variable heat delivery to accommodate changing heat requirements.
- All system operation is controlled and monitored from the heat module control panel
- Temperature control and fuel usage is automatic.
- 8-light system operation feature for easy system troubleshooting.
- Fluid circulation system is low pressure and atmospherically vented. There is no chance of an explosion or line burst due to pressure build-up. No special boiler certification is required to operate the system.
- Quick-connect hose couplers, “no-drain” fluid lines and a “rapid air elimination” feature ensures quick setup-and-go operation.
- A transport trailer is available and is specifically designed to carry the Dryair 2000-1200 central heating module.

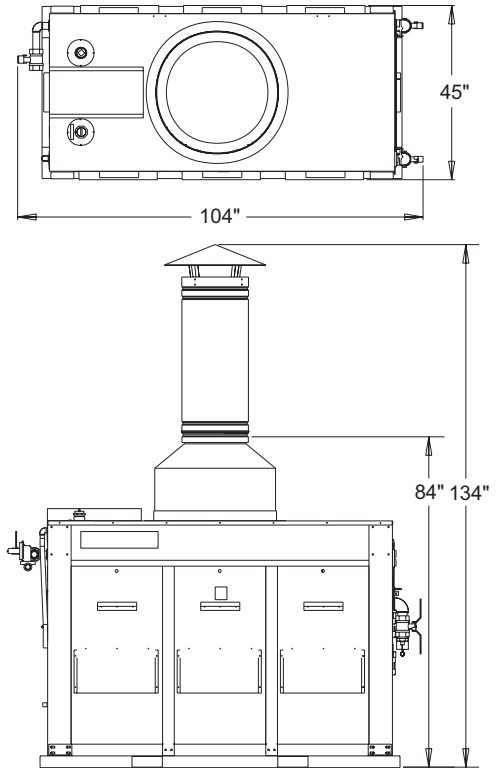

### Specifications

Type.....- Staged output, electric spark ignition  
 Temperature Range.....- 120°F to 200°F (49°C to 93°C)  
 Fuels specs  
 ...Natural gas fired  
 .....\*Input capacity.....- 1,233,000 BTU/H  
 .....\*Output capacity.....- 1,023,390 BTU/H  
 .....Gas pressure range....- 6" to 14" W.C.  
 .....Manifold gas pressure- 3.5" to 4" W.C.  
 .....Consumption - max....- 1,233 CU.FT/H (34.9 CU.M/H)  
 Propane fired  
 .....\*Input capacity.....- 1,134,360 BTU/H  
 .....\*Output capacity.....- 941,544 BTU/H  
 .....Gas pressure.....- 11" W.C.  
 .....Manifold gas pressure- 10" to 11" W.C.  
 .....Consumption - max....- 12.4 US GAL/H (46.9 L/H)  
 Control & monitoring.....- Full gauge panel monitoring circulation fluid temperatures & pressures, fuel pressures  
 .....- 11-light system operation feature for easy system troubleshooting.  
 Weight.....- 1,815 LBS. (823 KG)  
 Electrical.....- 115/230 V, single phase, 60 Hz, 30 Amps  
 Loading - standard.....- Forklift pockets on all four sides

Module fluid circulation system  
 ...Basic features.....- Atmospherically vented low pressure system, adjustable fluid temperature control, auto pressure by-pass for pump protection and variable flow demands, auto temperature bypass for heat exchanger protection.  
 ...Heat transfer fluid (HTF) - Non-toxic propylene glycol / water mixture, freeze protected  
 ...Primary lines & couplers - 2" fluid circulation lines, 2" ball valves, 2" Kamlock quick-couplers  
 ...Circulation pump.....- 2 HP, 80 GPM (364 LPM) @ 30 P.S.I.  
 ...Lock-out.....- Locks out primary “supply” & “return” fluid circulation valves and control panel  
 Optional  
 ...Transport trailer  
 ...Skyhook frame.....- Steel frame with four corner lifting eyelets, weld attach to water heater module base  
 ...Gas conversion.....- Propane or natural gas burner trays and gas trains

\* For every 1000 ft. increase in elevation after 2000 ft, input BTU's are derate by 4%.



**Heat Thaw Cure Dry**